

CPF25 Pedestal Mount Charging Stations



Installation Guide

Contents

1 Before You Install

Site Prerequisites	1-1
Required Tools.....	1-1
Overview of Steps	1-1
Check Shipping Boxes for Correct Contents.....	1-2

2 Install the Pedestal

Step 1: Mount and Level the Pedestal.....	2-1
Step 2: Install Pedestal Covers.....	2-2

3 Install Bracket and CMK

Preparation (stations without Cord Management)	3-1
Preparation (stations with Cord Management).....	3-2
3.1 Single Station (no Cord Management).....	3-3
3.2 Single Station with Cord Management.....	3-5
3.3 Dual Station (no Cord Management).....	3-7
3.4 Dual Station with Cord Management.....	3-10

4 Install Station(s) and Charging Cord(s)

Step 3: Mount the Station(s)	4-1
Step 4: Connect the Service Wiring	4-2
Step 5: Connect the Charging Cord(s).....	4-3
Step 6: Attach the Station Covers	4-4
Step 7: Attach the Charging Cord(s) to the CMK	4-5

5 Prepare to Activate on ChargePoint

You Will Need	5-1
Overview of Steps	5-1
Step 1: Pinpoint the Station(s)	5-2
Step 2: Document the Radio Group	5-3
Step 3: Complete the Post-Installation Checklist.....	5-4

6 Troubleshooting

APPENDIX A: Specifications and Wiring

APPENDIX B: Prepare Installation Site

APPENDIX C: Install the Power Share Kit

APPENDIX D: Install or Replace Signs

APPENDIX E: Limited Product Warranty

Before You Install

You must be a licensed electrician and complete an online training class (<http://chargepointuniversity.netexam.com/>) to become a ChargePoint Certified Installer, and to get a login for ChargePoint. If you do not complete this training, you will be unable to complete the installation process.



DANGER: RISK OF SHOCK

Turn off the circuit breaker and do not restore power until installation is complete. Failure to follow these instructions could result in shock or electrocution.

Site Prerequisites

Ensure that the location of the installation site is appropriate and you are ready to install the CPF25:

- The CPF25 must be located within 150' line-of sight from a CPGW (ChargePoint Gateway).
- Ensure that the appropriate wiring, circuit protection, and metering is in place at the installation location by reviewing the specifications, wiring diagrams, and grounding requirements described in Appendix A.
- Prepare the installation site by following the instructions in Appendix B. The mounting template for the pedestal is stapled into the center fold of this document and a PDF version is available at <http://www.chargepoint.com/support-guides/>. Ensure the PDF version is accurate by printing it at 100% scale on 11" x 17" paper and then verifying at least one dimension.

Required Tools

- Ratchet and 3/8" (10 mm) and 7/16" (11 mm) Sockets
- 1/2" Drive Torque Wrench (rated to at least 100 ft-lbs)
- 15/16" (24 mm) 6-point Deep Socket, for 5/8" nut
- Adjustable Wrench
- Bubble Level
- #2 Phillips Screwdriver
- Wire Stripper
- Voltage Tester
- T10 Torx Driver

NOTE: The tools listed above do not include the tools and supplies needed to prepare the installation site (described in Appendix B).

Overview of Steps

1. Check Shipping Boxes for Correct Contents (described on the next page)
2. Install the Pedestal (see Section 2)
3. Attach Bracket (and CMK, if applicable) to Pedestal (see Section 3)
4. Install the Stations and Charging Cords (see Section 4)
5. Prepare to Activate on ChargePoint (see Section 5)

Check Shipping Boxes for Correct Contents

Main Unit

Each main charging unit (one or two, depending on whether you ordered a single or dual station model) ships in a box containing:

- Station (1)
- Cover (1)
- Mounting Skirt(1)
- Wire Cover (1)
- 3/16" Drill Bit (1)*
- 1/4" X 2" Lag Screws (3)*
- Driver Bit (1)
- 1/4"-20 x 3/4" Hex Bolts (2)
- 1/4"-20 x 3/8" Phillips Screw (1)
- T10 Torx Screws (2)
- Spare Activation Label (1). A duplicate label is attached to the inside of the main unit. KEEP this spare label because it contains important information that is needed to activate the station on ChargePoint (Section 5).

**Not used in pedestal mount installations. These can be discarded.*

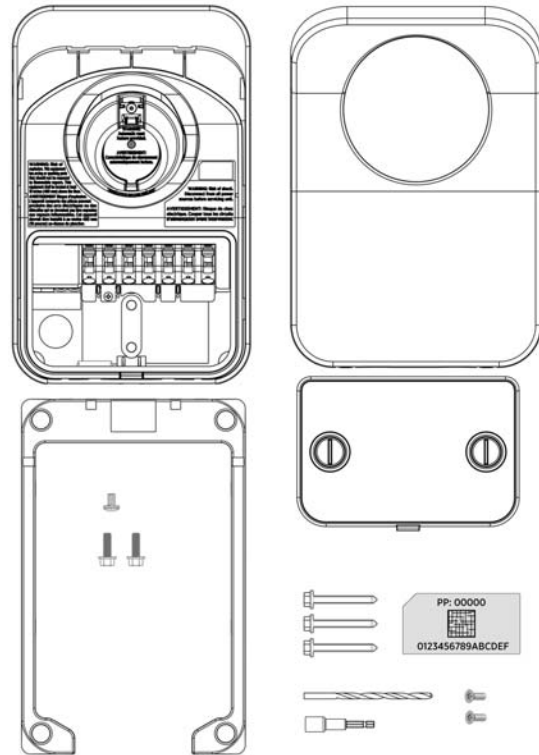

Charging Cord

Each charging cord (one or two, depending on whether you ordered a single or dual station model) ships in a separate box. If you ordered the Cord Management Kit (CMK), the cord(s) includes integrated clamps.

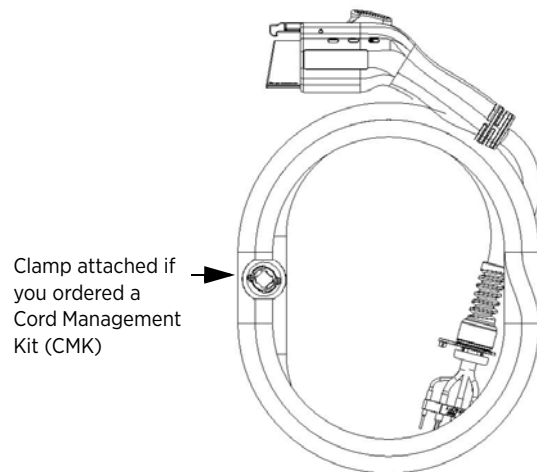

Pedestal

- Main body
- Pedestal Covers (3)*
- Pedestal CMK Spacer (attached)
- 8-32 X 3/8" Screws (4)

*Only two pedestal covers are needed. One can be discarded depending on whether a Cord Management Kit (CMK) is being installed.

NOTE: To prepare the installation site for installing a pedestal mount, you will also need the contents of the Pedestal Mount Kit, which ships separately (see Appendix B).



Bracket Kit

The contents of the bracket kit varies depending on the specific model ordered.

Single Station (no Cord Management)

- Bracket
- 10-32 x 4" screws (4)
- Lock Washers (4)

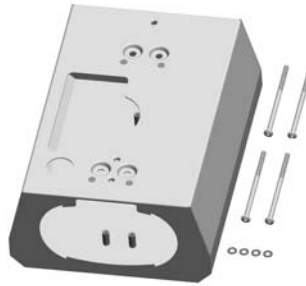

Single Station with Cord Management

- Bracket
- ¼ - 20 x 4" Screws (4)
- Lock Washers (4)



Dual Station (no Cord Management)

- Main Bracket
- Bottom Bracket Cover
- Internal Bracket
- 10-32 x 4" screws (4)
- #8 - 32 x 3/8" Screws (8)
- Nylon Spacers (2)
- Lock Washers (4)

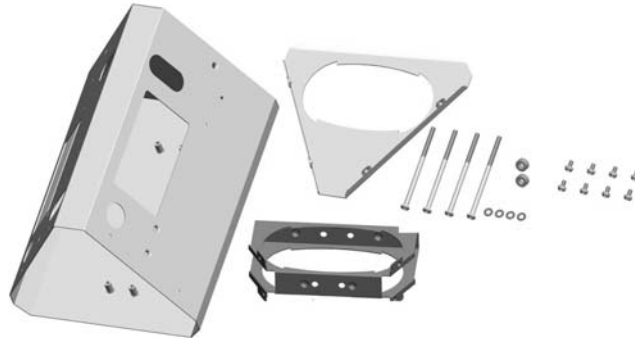

Dual Station with Cord Management

- Main Bracket
- Top Internal Brace
- Bottom Internal Brace
- ¼ - 20 x 4" Screws (4)
- #8 - 32 x 3/8" Screws (8)
- Spacers (2)
- Lock Washers (4)

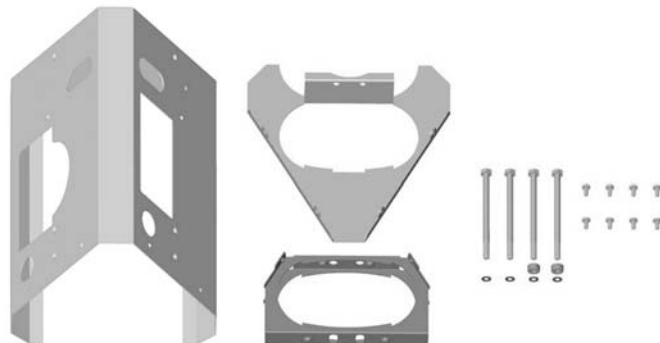

Cord Management Kit (CMK)

If you ordered the optional cord management kit, it ships in a box containing:

- Cord management assembly with pre-installed “EV CHARGING ONLY” sign (1)
- Cable clamps (2 extra sets)

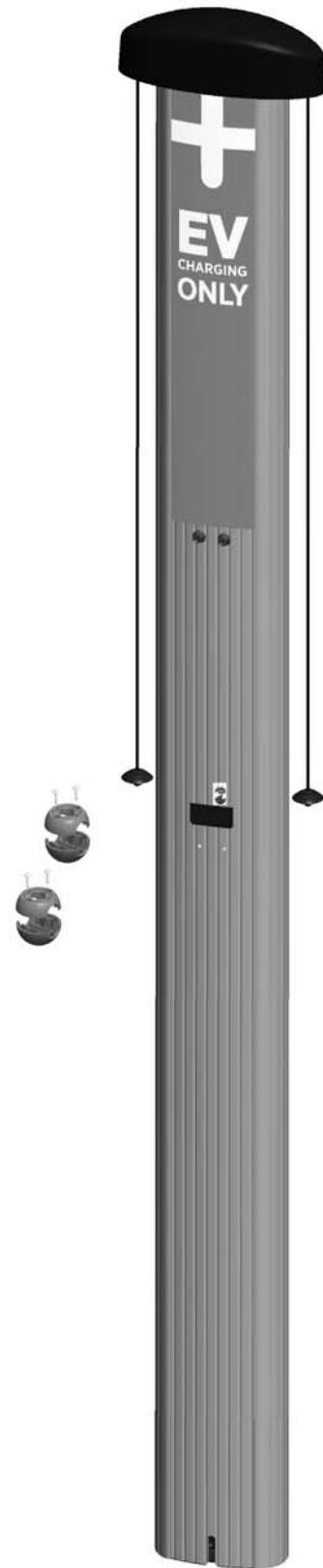

Install the Pedestal

Before installing the pedestal, you must prepare the installation site.
For detailed instructions, see Appendix B.

Step 1: Mount and Level the Pedestal

- Pull servicing wiring up through the conduit, leaving approximately 6' extending out of the conduit.
- Place the pedestal over the conduit, ensuring the long curved edge of the base plate (which is the cut-out for a cable management kit - CMK) is located at the back of the station.
- Ensure the pedestal is level.
- Fasten the pedestal to the bolts extending into the base plate using the 5/8" nuts and washers and the 1/2" drive torque wrench with 15/16" deep socket, as shown.
- Adjust the lower nuts as necessary to ensure the mounting pole is level.
- When level, tighten the nuts on top of the base plate to at least 90 ft-lbs (122 Nm).
- Route the service wiring up through the pedestal.

IMPORTANT ! Ensure the pedestal is level by adjusting the nuts underneath the base plate. Verify accuracy after each adjustment by positioning the level at various locations on the base plate and on the pedestal.

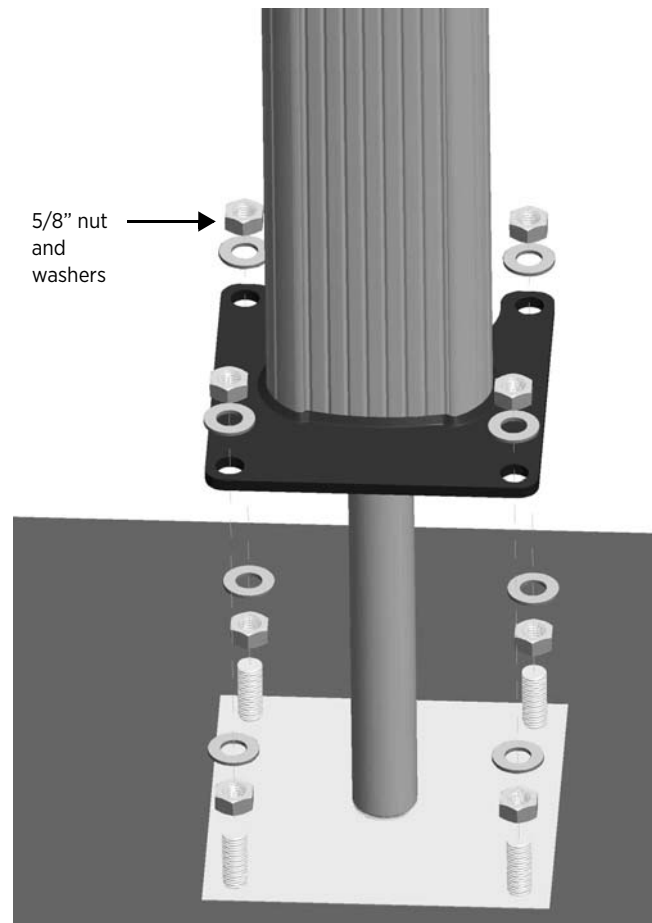

Step 2: Install Pedestal Covers

- Position the two-piece pedestal covers over the bottom of the pedestal, as shown.
- Insert the two 8-32 x 3/8" screws into each side of the pedestal, as shown.
- Tighten the screws using a Phillips screwdriver.

NOTE: As illustrated, the cover you use at the back of the pedestal depends on whether your station includes a Cord Management Kit (CMK). Discard the extra cover.

If not using a cord management kit, use the back pedestal cover without the indentation:

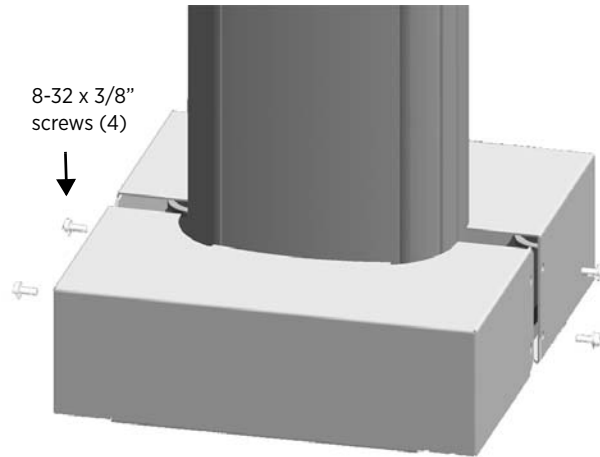

If using a cord management kit, use the back pedestal cover with the indentation:

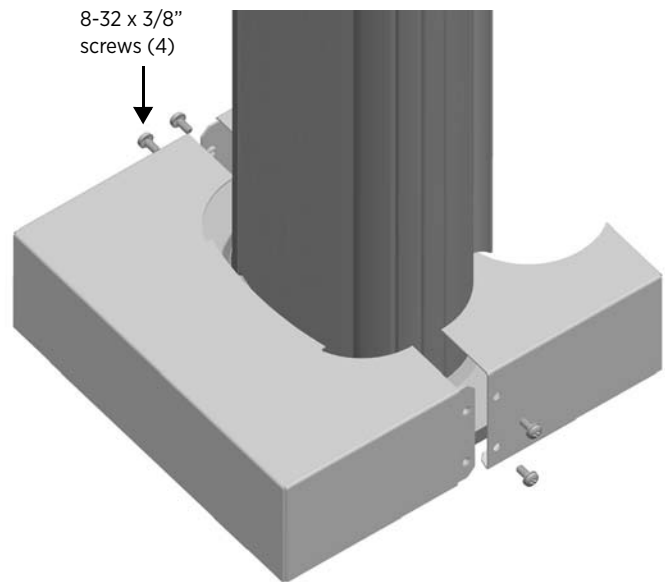

Install Bracket and CMK

IMPORTANT !

This section describes how to attach the mounting bracket and its associated components to the pedestal. Follow the steps associated with the particular CPF25 model you are installing:

Single Station (no Cord Management) - see page 3-3

Single Station with Cord Management - see page 3-5

Dual Station (no Cord Management) - see page 3-7

Dual Station with Cord Management - see page 3-10

Before proceeding with the installation, follow one of the preparation steps below. The preparation step is different depending on whether your CPF25 includes the Cord Management option.

Preparation (stations without Cord Management)

Slide the spacer at the back of the pedestal upward to remove. Discard the spacer (this spacer is required only if you are installing a cord management kit).

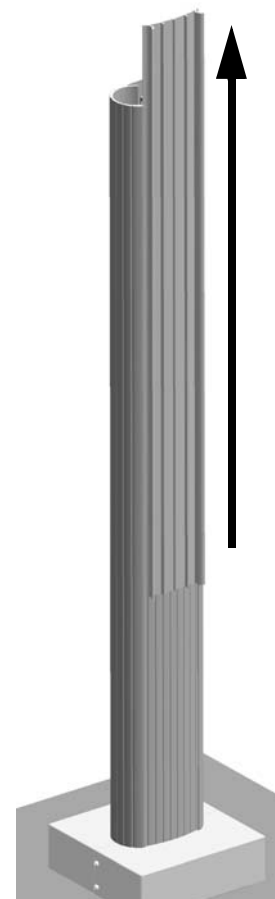

Preparation (stations with Cord Management)

If your station has a Cord Management Kit, follow these steps to prepare the CMK for mounting:

- Position the CMK packaging so its bottom is located near the base of the wall where you are installing the charging station..

IMPORTANT: Do not unwrap the ropes.

- **Remove and discard the two 3/8" drive shipping screws from the front face of the CMK.**

NOTE: When you remove the shipping screws, the counterweights are free to move in either direction. Therefore, do not tilt or carry the assembly with the top end lower than the bottom end.

- Remove the foam packaging.

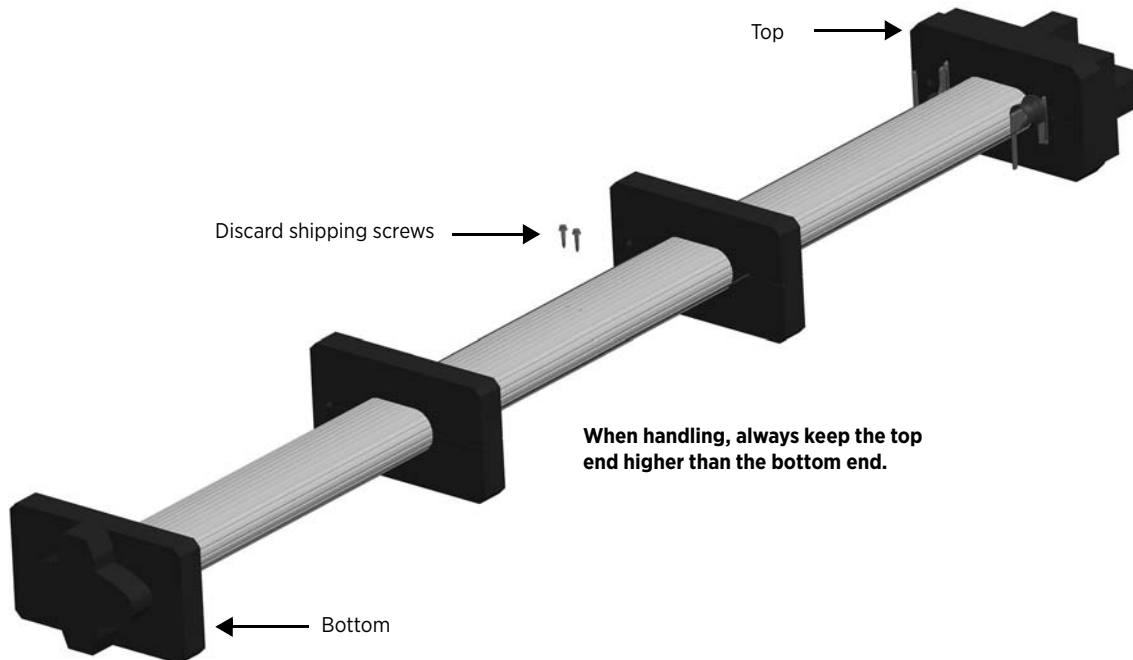

3.1 Single Station (no Cord Management)

1. Remove the ground lug using a 7/16" wrench (save the 1/4"x20 screws to reinstall).
2. Connect the ground wire from the service wiring to the ground lug, then run a 10-gauge ground wire from the ground lug through the wiring opening in front of the pedestal.
3. Reinstall the ground lug to the pedestal using the 7/16" wrench and the two 1/4"x20 screws you removed.
4. Run the remaining service wiring through the opening in front of the pedestal.

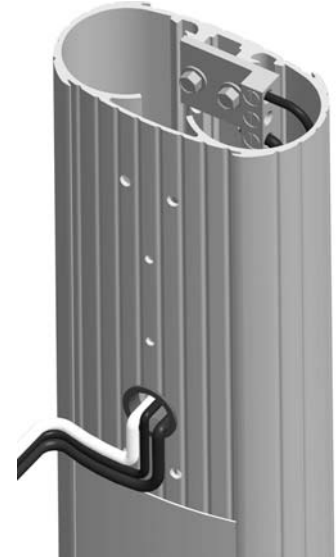

5. Slide the bracket over the pedestal. The two holes at the top and two holes at the bottom of the bracket must align with the corresponding holes in the pedestal.

CAUTION: The bracket must slide over the service wiring. Lay the wiring as flat as possible to prevent the wires from damage.

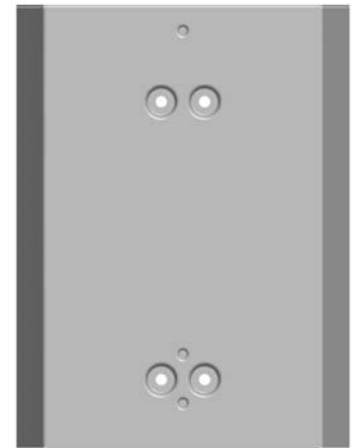

6. Fasten the bracket to the pedestal by inserting the four 10/32 x 4" screws and lock washers through the bracket and into the stand-offs on the pedestal. Tighten using a Phillips screwdriver.
7. Route the service wiring through the wiring hole in the front of the bracket.

You have now completed installation of the bracket and are ready to install the station and charging cord as described in the Section 4.

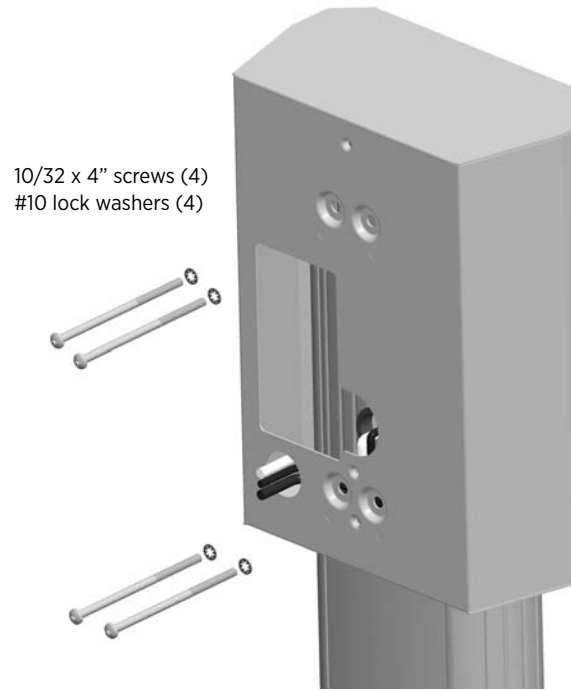

3.2 Single Station with Cord Management

1. Remove the ground lug by removing its two screws using a 3/8" socket wrench (save the screws to reinstall in step 3 below).
2. Connect the ground wire from the service wiring to the ground lug, then run a 10-gauge ground wire from the ground lug through the wiring opening in front of the pedestal.
3. Reinstall the ground lug to the pedestal using the 3/8" wrench and the two screws you removed.
4. Run the remaining service wiring through the opening in front of the pedestal.
5. Slide the bracket over the pedestal. The two holes at the top and two holes at the bottom of the bracket must align with the corresponding holes in the pedestal.

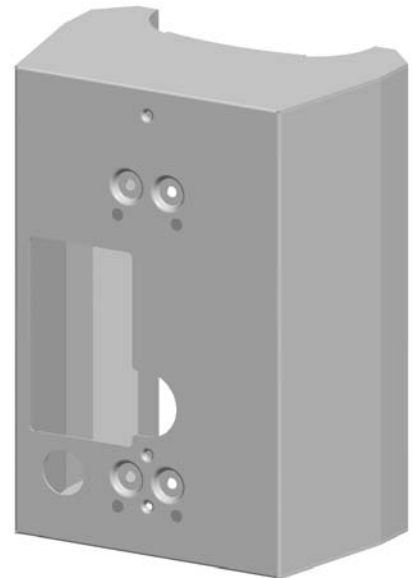

6. Insert the four 1/4"-20 x 4" hex screws and lock washers through the bracket and pedestal.
7. Route the service wiring through the wiring hole in the front of the bracket, as shown.

1/4"-20 x 4" hex screws (4)
1/4" lock washers (4)



8. Position the slot at the bottom of the CMK onto the screw at the bottom of the pedestal and hold the CMK against the back of the pedestal while aligning the four 4" screws (inserted in the previous step) into the corresponding holes in the CMK.

NOTE: The spacer on the pedestal should slide into the ridges on the CMK.

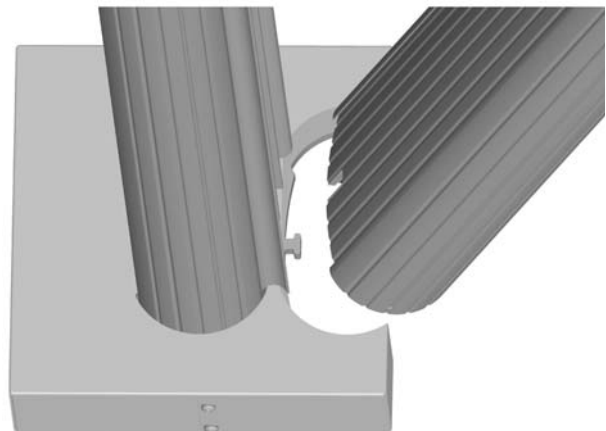

9. While holding the bracket and CMK in place, tighten the 4" screws into the CMK using the 7/16" socket.

You have now completed installation of the bracket and CMK and are ready to install the station and charging cord as described in the Section 4.

3.3 Dual Station (no Cord Management)

1. Slide the bottom bracket brace over the pedestal, allowing it to drop to the bottom.

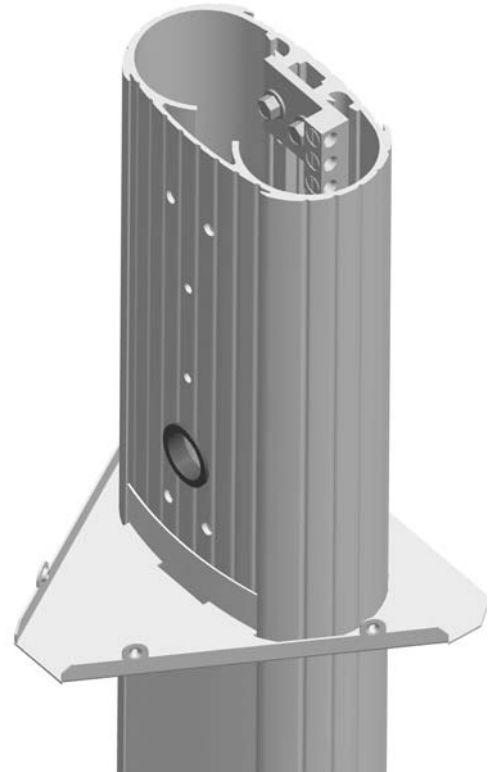

2. Remove the ground lug using a 7/16" wrench (save the 1/4"x20 screws to reinstall).
3. Connect the ground wire from the service wiring to the ground lug, then run two 10-gauge ground wires from the ground lug through the wiring opening in front of the pedestal.
4. Reinstall the ground lug to the pedestal using the 7/16" wrench and the two 1/4"x20 screws you removed.
5. Run the remaining service wiring through the opening in front of the pedestal.

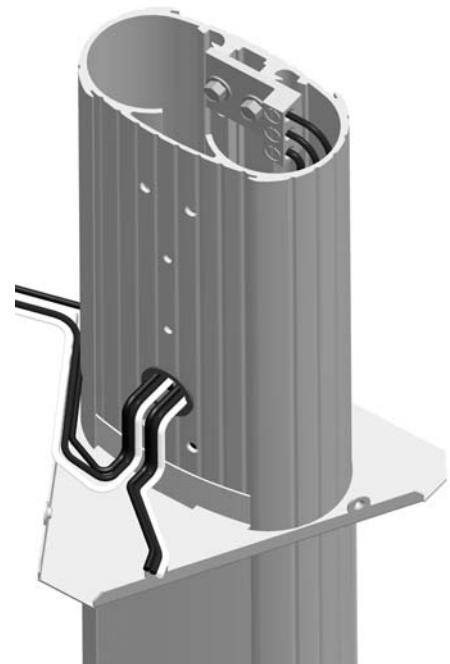

STOP!

If installing the Power Share kit, follow the steps in Appendix B before continuing with the next step.

- Slide the main bracket over the pedestal, aligning the holes in the main bracket with the corresponding holes in the pedestal.

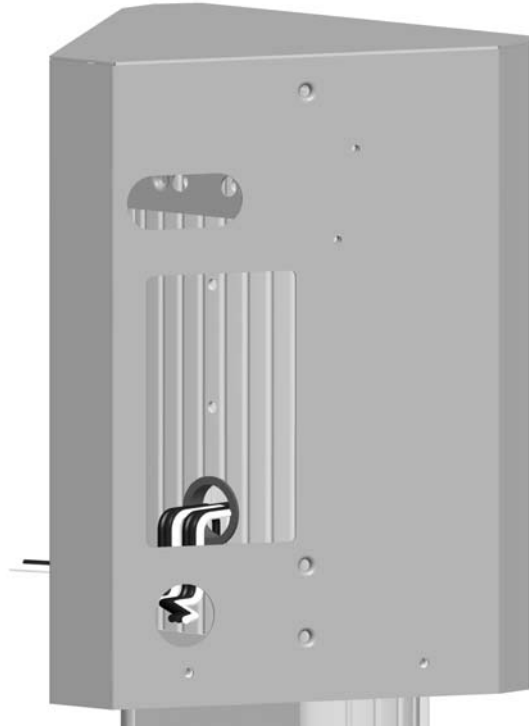

- Fasten the main bracket to the pedestal using 10-32 x 4" screws and lock washers at the top and two 10-32 x 4" screws and spacers at the bottom.
- Route the service wiring through the wiring hole on each left corner of the main bracket fronts.

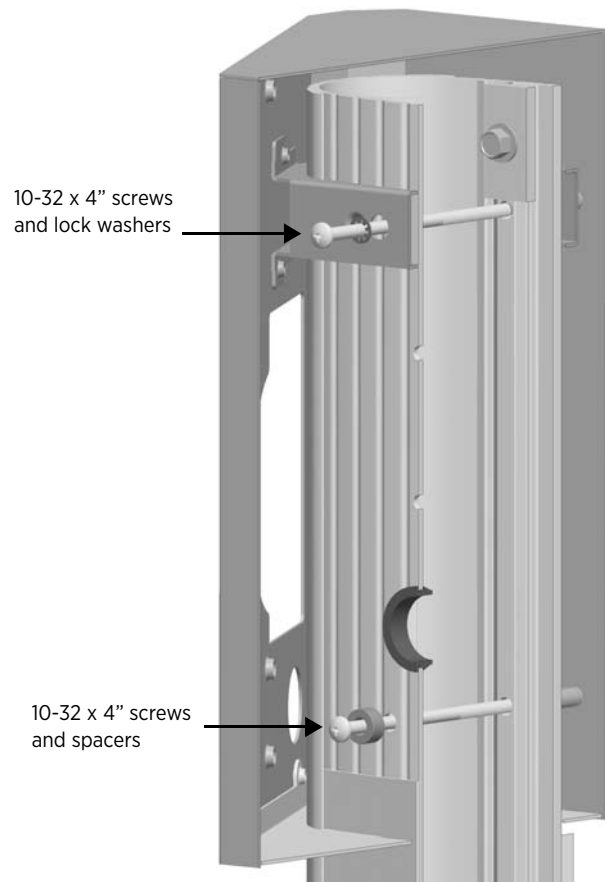

- Slide the bottom brace up, aligning its holes with the main bracket and fastening to the main bracket using two #8 - 32 x 3/8" screws on each side.

You have now completed installation of the bracket and are ready to install the stations and charging cords as described in the Section 4.

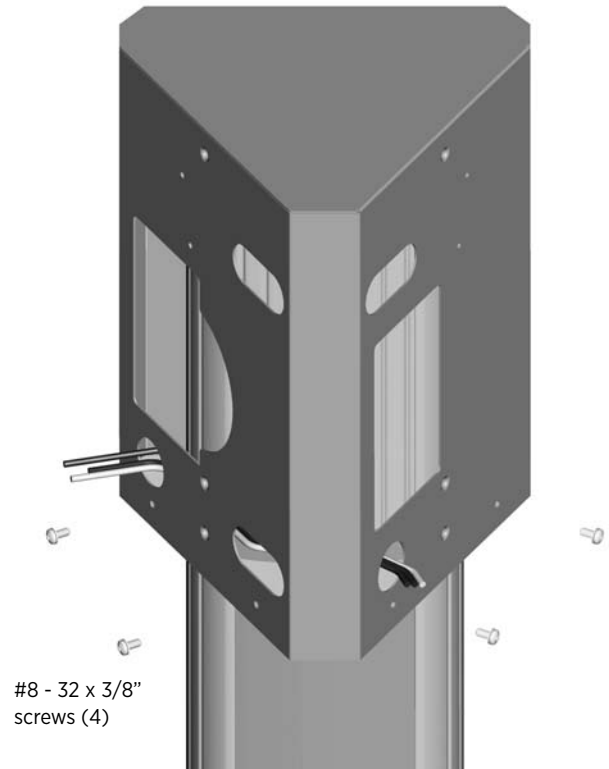

3.4 Dual Station with Cord Management

1. Slide the bottom bracket brace over the pedestal allowing it to drop to the bottom.
2. Remove the ground lug using a 7/16" wrench (save the two 1/4"x20 screws to reinstall).
3. Connect the ground wire from the service wiring to the ground lug, then run two 10-gauge ground wires from the ground lug through the wiring opening in the front of the pedestal.
4. Reinstall the ground lug to the pedestal using the 7/16" wrench and the two 1/4"x20 screws you removed in Step 2 above.
5. Run the remaining wiring through the opening in the front of the pedestal.

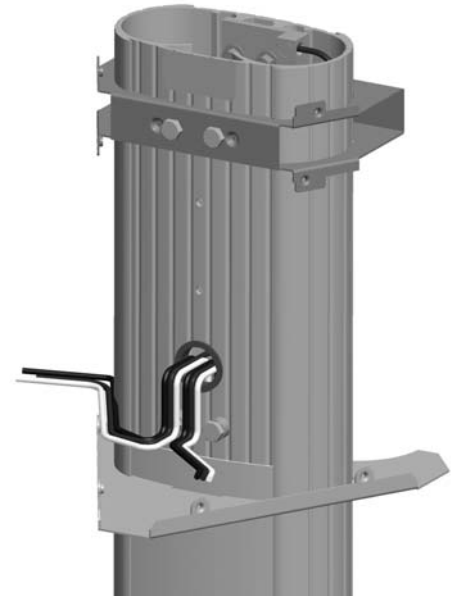

STOP! If installing the Power Share kit, follow the steps in Appendix B before continuing.

6. Insert the four 4" long 1/4"x 20 screws. Install lock washers on each screw and spacers on the two lower screws.

1/4"x 20 x 4" screws (2)
lock washers (2) →

1/4"x 20 x 4" screws (2)
lock washers (2)
spacers (2) →

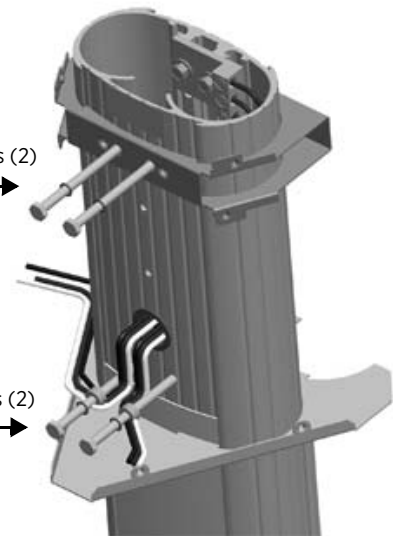

7. Position the slot at the bottom of the CMK onto the alignment tab at the bottom of the pedestal and hold the CMK against the back of the pedestal, while aligning the four 4" screws (inserted in the previous step) into the corresponding holes in the CMK.

NOTE: The spacer on the pedestal should slide into the ridges on the CMK.

8. While holding the bracket and the CMK in place, tighten the 4" screws into the CMK using the 7/16 socket wrench.

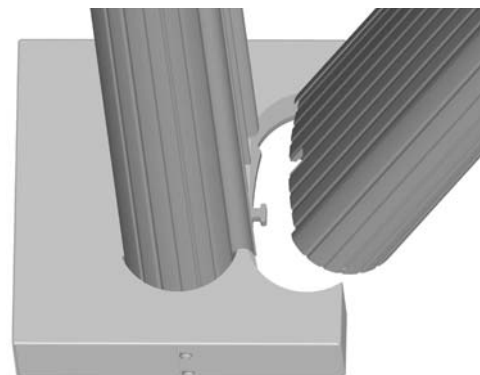

9. Slide the main bracket over the pedestal, aligning the holes in the main bracket with the corresponding holes in the top internal brace.
10. Route the service wiring each of the wiring holes located in the left front corner of each main bracket.

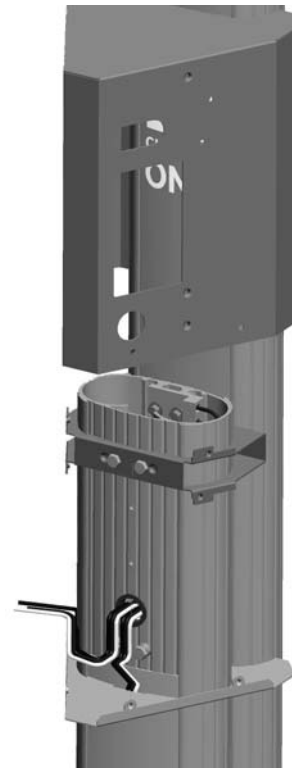

11. Fasten the main bracket to the pedestal by screwing four 8-32x3/8" screws into the internal bracket.

8-32x3/8"
screws (4)

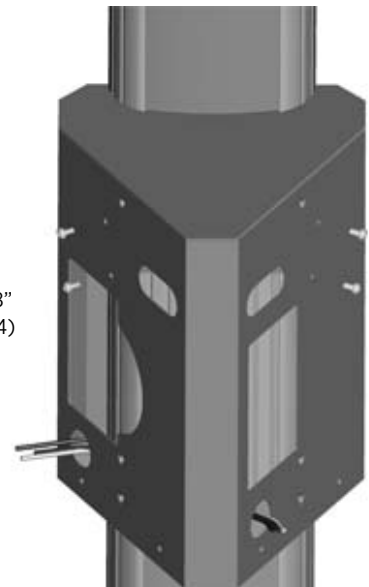

- Slide the bottom brace up, aligning its holes with the main bracket and fastening it to the main bracket using two 8-32x3/8" screws on each side.

You have now completed installation of the bracket and CMK and are ready to install the stations and charging cords as described in the Section 4.

8-32x3/8"
screws (4)

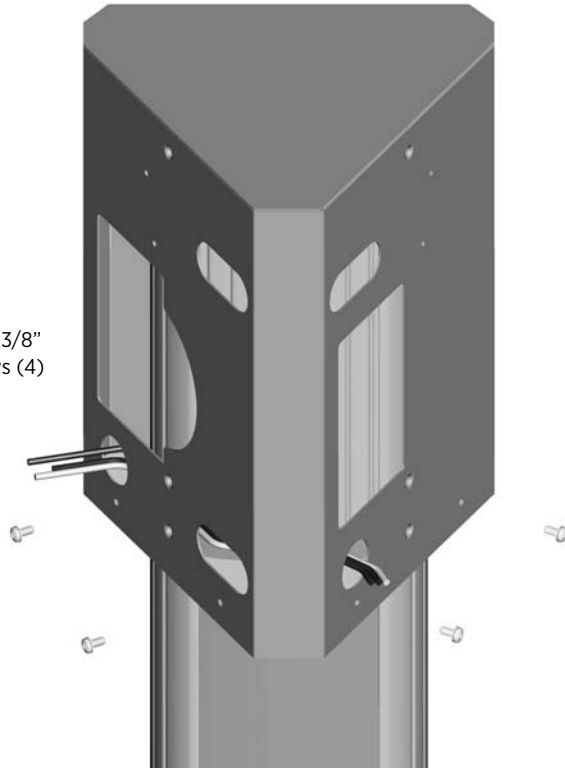

Install Station(s) and Charging Cord(s)

4

Step 3: Mount the Station(s)

Follow these steps for each station:

- Insert a 1/4" - 20 x 3/8" screw into the top center hole on the front bracket using a #2 Phillips screwdriver but leave the screw protruding approximately 1/4" to create a 1/8" gap between the back of the screw head and the bracket.
- Position the mounting skirt against the back of the main unit, as shown, and hold it in place while hanging the main unit on the protruding top screw.
- Route the service wiring through the hole in the back of the main unit.
- Hang the main unit on the top protruding screw on the bracket.
- Secure the main unit by inserting the two 1/4" - 20 x 3/4" hex screws through the main unit (near the bottom center) and into the bracket, as shown. Tighten using a 3/8" hex driver.

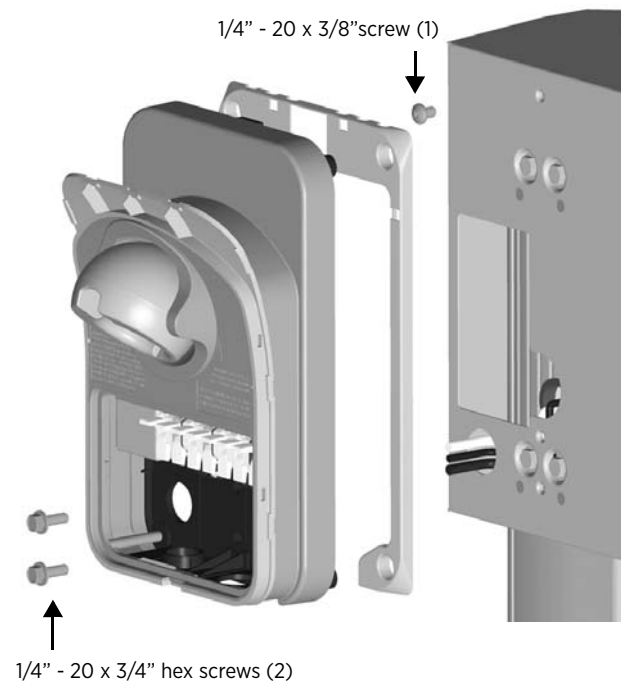

Step 4: Connect the Service Wiring

Follow these steps for each station:

1. Trim the service wiring to remove excess length while ensuring that the wiring can easily reach the connectors on the charging station's terminal block.
2. Strip each wire 1/2".
3. Fully insert wires into the connectors on the left side of the terminal block, as shown.
4. On each connector, press the white clip all the way down until it snaps into place.

⚠ CAUTION: Ensure each wire is fully inserted into the connector before pressing it into place with the white clip.

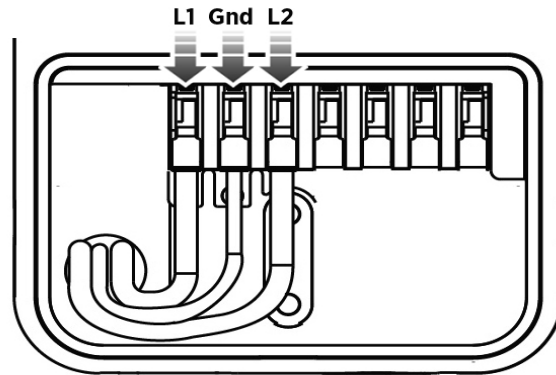

Step 5: Connect the Charging Cord(s)

Follow these steps for each charging cord:

1. Remove the cable clip connected to the wiring end of the cord, but do not discard it.

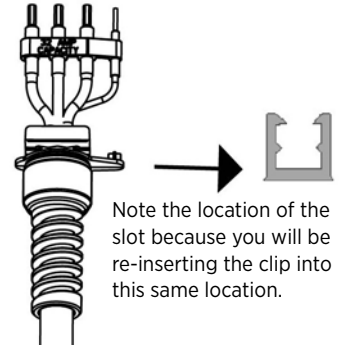

2. Insert the wire ends into the opening on the right side of the bottom of the station, pushing up until the silver conductors are no longer visible. Insert the wires into the corresponding connectors on the right side of the terminal block, as shown.
3. On each connector, press the white clip all the way down until it snaps into place.

⚠ CAUTION: Ensure each wire is fully inserted into the connector before pressing it into place with the white clip. Pay particular attention to the small rightmost wire.

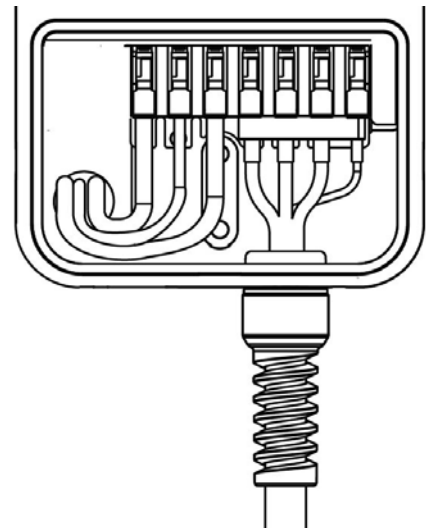

4. Attach the cable clip by pushing the cord upward and sliding the cable clip into the slot on the strain relief until it snaps into place.

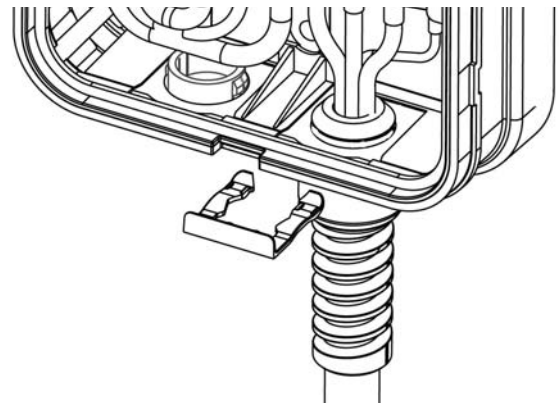

Step 6: Attach the Station Covers

Follow these steps for each station:

1. Attach the wire covers:
 - Place the wire cover over the exposed wiring on the terminal block.
 - Using a coin, lock the wire cover in place, as shown.

NOTE: To avoid damage, do not use a screwdriver.

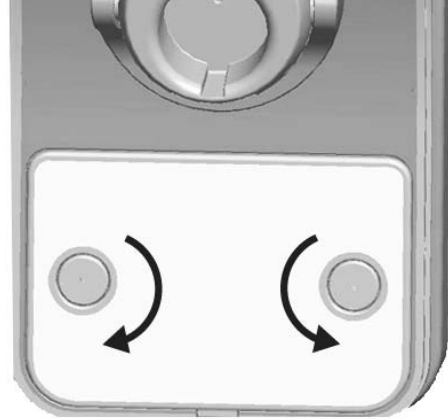

2. Place the cover over the front of the station.



3. Fasten the front covers by inserting two T10 Torx screws into the bottom of the station, as shown.

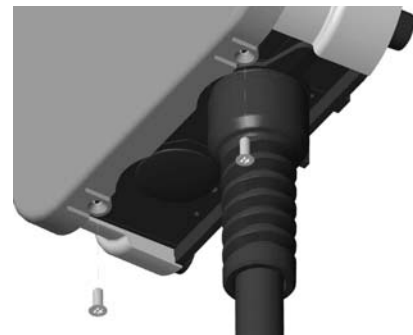

T10 Torx screws (2)

Step 7: Attach the Charging Cord(s) to the CMK

If your station is equipped with a cord management kit, follow these steps to connect each charging cord to the nylon rope that keeps the charging cord in place:

1. Gently extend the charging cord all the way out and away from the station. Rotate the plugs as needed to remove any twist or kinks.
2. Align the knot bearing on each rope to its corresponding mating feature on the cable clamp. Turn the knot bearing clockwise approximately 1/4 turn. You may need to push down while turning the knot bearing.

NOTE: If you are installing a single-station CPF25, attach the charging cord to the LEFT side of the station to minimize interference with the card reader.

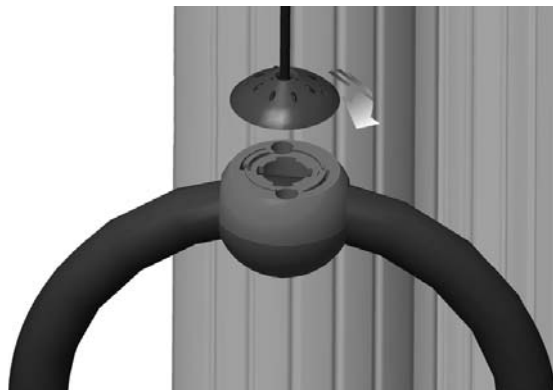

The physical installation of the CPF25 is now complete and you are ready to prepare the station for activation on ChargePoint, as described in the next section.

Prepare to Activate on ChargePoint

Before leaving the installation site after completing the physical installation of the CPF25, you must prepare the station(s) for activation by following the steps described in this section.

You Will Need

- The CPF25's MAC address and activation password (this information is printed on an activation label that is affixed to the CPF25's main unit and a spare label is included in the shipping box with each main unit).
- The exact location (to the parking space) where the CPF25 is physically installed.
- A smart phone with Internet access.
- Installer account information (user name and password) on ChargePoint. This was provided upon completion of training.

Example of activation label:

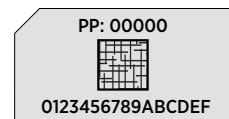

Overview of Steps

1. Pinpoint the Station(s) (see page 5-2)
2. Document the Radio Group (see page 5-3)
3. Complete the Post-Installation Checklist (see page 5-4)

These steps are detailed in the remainder of this section.

NOTE: If installing a dual-station CPF25, you must perform these steps for each station.

Step 1: Pinpoint the Station(s)

1. Using your smart phone, navigate to <https://m.chargepoint.com>.
2. Login to the ChargePoint mobile site from your smart phone with your installer credentials.
3. Enter the MAC address and activation password printed on the CPF25's activation label, and touch Next.



4. Confirm that you are installing a new CPF25 charging station.
5. When prompted, touch OK to share your GPS location data with the ChargePoint mobile site.
6. When prompted, touch OK to review the station's location on Google™ Maps.
7. Review the station address and zoom in to review the initial position of the station's pin on the map.
8. Using your finger, move the pin to the correct parking spot location.
9. If needed, manually adjust the address of the station's location.
10. Take a picture of the station using your smart phone, then scroll down to "Upload a Station Picture" and choose the station picture.
11. Add helpful information for drivers.
12. Touch SUBMIT to pinpoint the station on the ChargePoint map.

Step 2: Document the Radio Group

A radio group consists of a ChargePoint Gateway and up to nine CPF25 charging stations that it communicate with over WiFi. For each radio group, attach the spare activation labels below to document how stations are organized. After completing this step and the checklist on the following page, provide this information to the person responsible for activating the gateway and the CPF25 charging stations. If installing multiple radio groups, use one page for each radio group (this page is included in all Installation Guides).

Gateway	attach spare activation label here		
CPF25	attach spare activation label here	CPF25	attach spare activation label here
CPF25	attach spare activation label here	CPF25	attach spare activation label here
CPF25	attach spare activation label here	CPF25	attach spare activation label here
CPF25	attach spare activation label here	CPF25	attach spare activation label here
CPF25	attach spare activation label here	CPF25	attach spare activation label here
CPF25	attach spare activation label here	<p>NOTE: Up to nine CPF25s can communicate with a ChargePoint Gateway.</p>	

Step 3: Complete the Post-Installation Checklist

Before leaving the installation site, complete this checklist for the CPF25. Then provide this information, along with the information on the previous page, to the person responsible for activating the CPF25.

Customer:

Name

Site Address

Contact

Installer:

Company

Address

Phone

Installer

Contact

- Earth ground connection is made to the ground lugs (where applicable).
- Service wiring has been fully inserted into the terminal block and all electrical connections are clean and snug.
- Electrical enclosures are clean and free of wire strands and metal shavings.
- All covers are installed and all fasteners are tightened.
- The LED located at the bottom of the ChargePoint Gateway is solid green (this can take up to 10 minutes).
- The parking area is clean and free of all packaging and debris.
- All pinpointing steps on the previous page have been complete.
- A white light is displaying around the CPF25's connector dock and its WiFi LED, located on the left side of the main unit's cover, is solid green (this can take up to 10 minutes).
- SHARED CIRCUITS ONLY: Specify panel & breaker numbers and apply spare activation labels below:

Panel ID #: _____ Breaker # _____

Troubleshooting

After installing the station(s), you must verify that:

- the output cable wiring is properly installed
- the small blue wire on the output cable is fully inserted into the connector on the terminal block
- wires are not laying parallel to the back face

Check the Status Light

When the station is powered on and activated, the status light on the front of the station illuminates as follows:



- OFF: Idle (including vehicle plugged in but not authorized)
- Pulsing Yellow: Authorization in progress
- Pulsing Green: Card is approved and schedule is set to delay charging
- Solid Green: Card is approved and station is ready to charge
- Pulsing Blue: Vehicle is charging
- Solid Blue: Vehicle is plugged in but is not yet charging (or vehicle is fully charged)
- Solid Red: Card is denied (temporary) or a fault has occurred (permanent)

Charging Cable Doesn't Move Freely

If your CPF25 is equipped with a Cord Management Kit and the charging cord does not extend or retract fully and smoothly, it is likely that its rope has come off the pulley and you must re-position it.

You will need:

T25 L-wrench

Follow these steps:

1. Using the T25 L-wrench, loosen the set screws on each side of the retractor below the top cap.

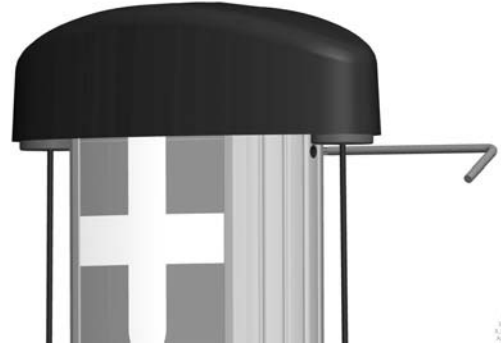

2. Each rope is attached to a weight that sits on a shelf. Pull the weight shelf up by pulling the rope located in the middle of the top cap.



3. Rotate the top cap so the weight controlling the rope that doesn't move freely is facing towards you.



4. Inspect the rope to ensure it is properly aligned onto the pulley.
5. Carefully lower the weight back into the retractor.
6. Rotate the top cap back into position and re-tighten the set screws to about 10 in-lbs.



Specifications and Wiring

A

Specifications

Electrical Input

	Input Current	Input Power Connection	Required Service Panel Breaker
Standard	32A	One 40A branch circuit	40A dual pole (non-GFCI type)
Service Panel GFCI	Do not provide external GFCI as it may conflict with internal GFCI (CCID)		
Wiring - Standard	3 Wire - L1, L2 plus Earth (no Neutral)		
Station Power	2.5W typical (standby)		

Electrical Output

Standard	7.7kW (240VAC @ 32A) / 6.7kW (208VAC @32A)
----------	--

Required Companion Products

Required for all CPF25 Stations	One ChargePoint Gateway USA/Canada Required for every nine CPF25 stations. Provided by ChargePoint free of charge and installed as part of the "make ready."
---------------------------------	--

Functional Interfaces

Connector Type	SAE J1772™
Cable Length - 6' Cable Management	18' (5.5 meters)
Cable Length - 8' Cable Management	23' (7.0 meters)
Overhead Cable Management System	Yes
Card Reader	ISO 15693 and ISO 1443

Safety and Connectivity Features

Ground Fault Detection	20mA CCID with auto retry
Open Safety Ground Detection	Continuously monitors presence of safety (green wire) ground connection
Plug-Out Detection	Power terminated per SAE J1772 specifications
Power Measurement Accuracy	+/- 2% from 2% to full scale (32A)
Power Report/Store Interval	15 minute, aligned to hour
Local Area Network	2.4/5 GHz Wi-Fi (802.11 a/b/g/n)
Cellular Coverage	The ChargePoint Gateway must be installed within 150 feet (line of sight) from the charging station and have adequate 3G CDMA (Verizon) or 3G GSM (AT&T) cellular coverage. The signal strength should be better than -90db (for example, -85db is better than -90db).

Safety and Operational Ratings

Enclosure Ratings	Type 3R per UL 50E
Safety and Compliance	UL and C-UL listed product per UL2594, UL2231-1, UL2231-2. NEC Article 625 compliant
Surge Protection	6kV @ 3000A. In geographic areas subject to frequent thunder storms, supplemental surge protection at the service panel is recommended.
EMC Compliance	FCC Part 15 Class B
Storage Temperature	-40°F to 140°F (-40°C to +60°C)
Operating Temperature	22°F to 122°F (-30°C to +50°C)
Operating Humidity	Up to 85% @ 122°F (+50°C) non-condensing
Non-Operating Humidity	Up to 95% at 50°C non-condensing
Maximum Charging Stations per 802.11 Radio Group	9. Each station must be located within 150 feet "line of sight" of a CPGWx gateway.

Indicators

WiFi LED	Yes
Fault Indicator per UL	Yes
Status LED	Yes

ChargePoint, Inc. reserves the right to alter product offerings and specifications at any time without notice, and is not responsible for typographical or graphical errors that may appear in this document.

Wiring Diagram

The following illustrations describes the wiring for installing a CPF25.

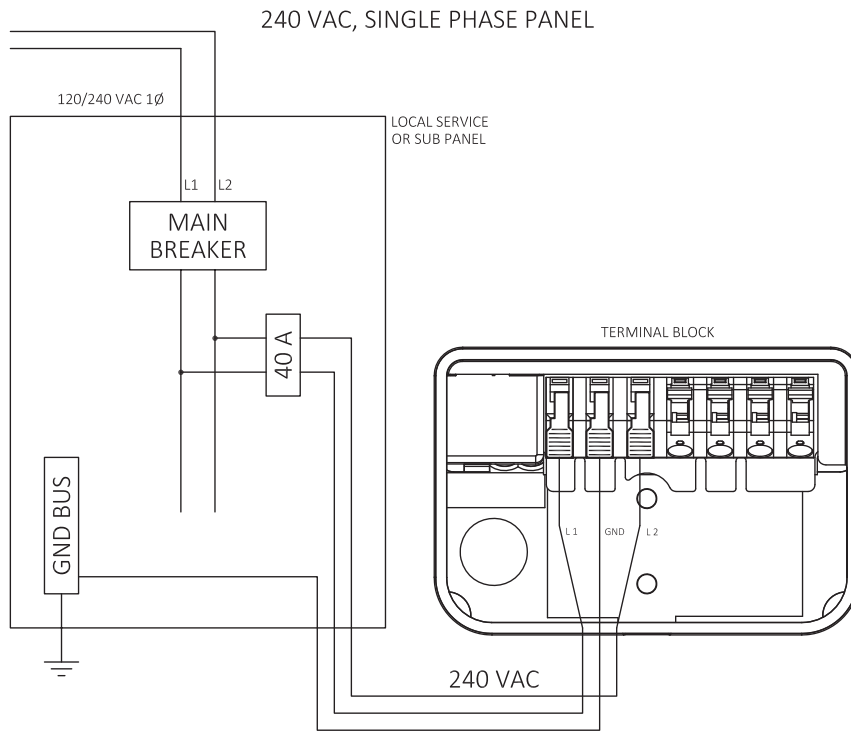

Panel needs **240V 40A** service



Tip: Requires a new, two-pole circuit breaker

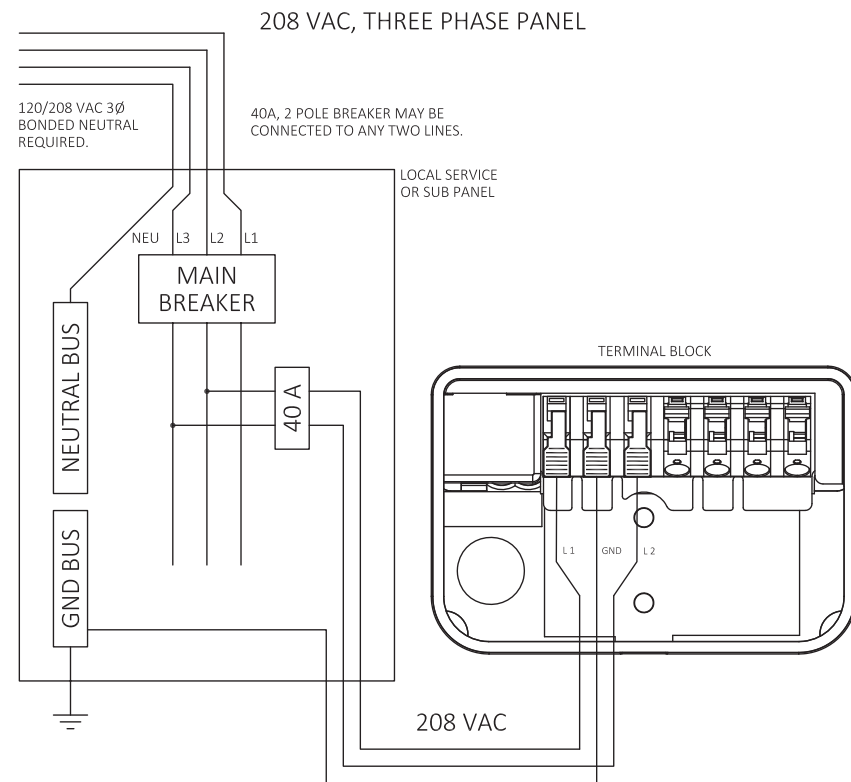

Grounding Requirements

The voltage of either line, relative to ground, must not fall below 80 volts. Because the voltage of either line relative to ground must not be allowed to fluctuate, use only center-grounded systems. Neutral is not used to power the station but must be properly connected to ground, at the panel or transformer, to provide the necessary voltage reference relative to ground.

Connect to these systems

In a wye system, connect the station to ANY two lines, as shown below.

In a delta system, connect the station to a center-tapped secondary only, where the center tap is bonded and the station is connected to L1 and L3. This allows voltages to remain constant regardless of other loads that may be using the lines.

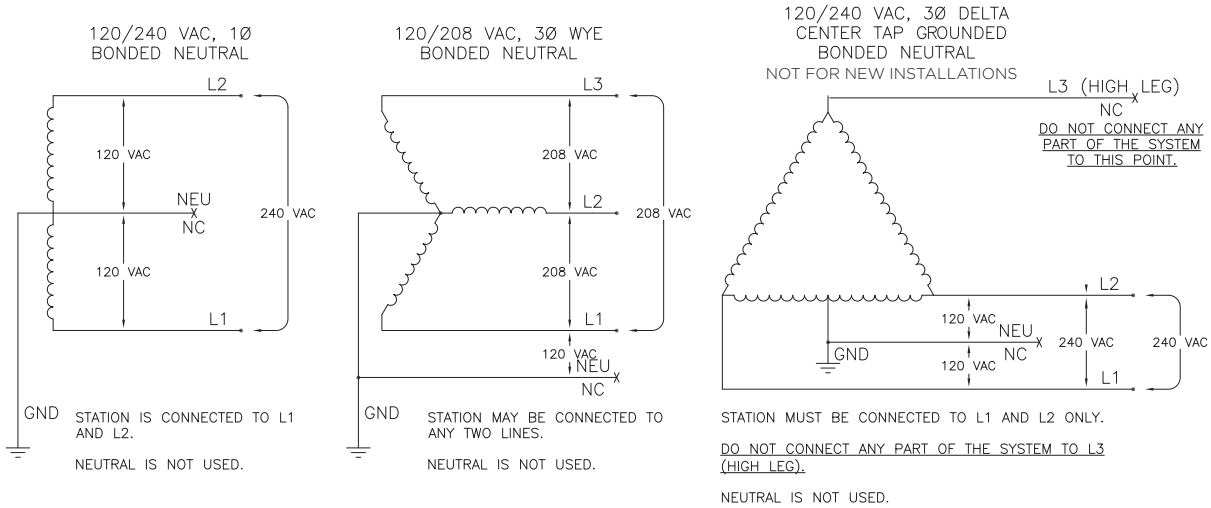

Do not connect to these systems

Do not connect ChargePoint stations to the following types of power sources:

- 120/208 VAC 3 phase wye, ungrounded
- 120/240 VAC 3 phase delta, corner-grounded
- Any system where the center point of the AC power source is not grounded

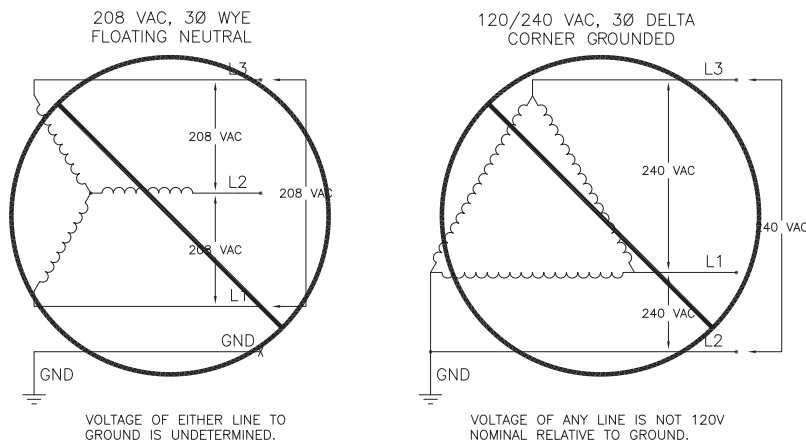

Prepare Installation Site

B

Before You Start

The CPF25's pedestal mount can be installed either:

- into the ground by casting into new concrete
- onto an existing concrete surface
- onto a stacked parking platform

The kit components you need to use, the tools required, and the installation steps vary depending on the type of installation. This appendix provides basic guidelines for these types of installations.

IMPORTANT: Always check local codes to ensure compliance. You may need to adjust the guidelines provided in this appendix to comply with codes that apply at your installation location.

Installation Overview

To install the CPF25 pedestal mount into the ground, you will need the components shown below. These components are included in the shipping box with the pedestal and can also be purchased from ChargePoint by ordering a CPF25 Pedestal Mount Kit.

- 8-32 X 3/8" Screws (4)
- 5/8" - 11 X 9" Grade 55 Bolts (4)
- 5/8" - 11 Hex Nuts (16)
- 5/8" Washers (12)
- Installation Template 75-001163-01 (stapled into the center of this Installation Guide)

***NOTE:** When installing onto an existing concrete surface, you will need only 6 Galvanized Hex Nuts and 6 Galvanized Washers. But you will need several consumables as described on page A-3.

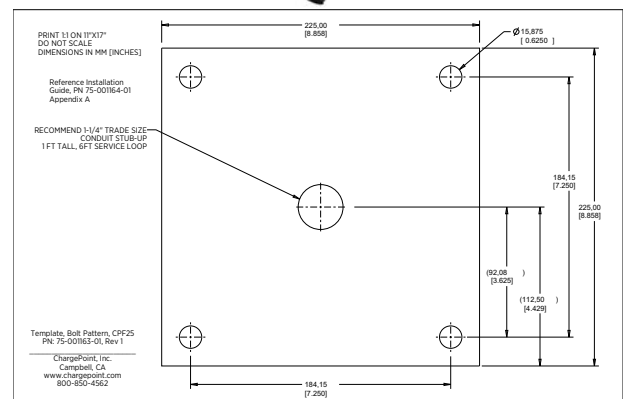
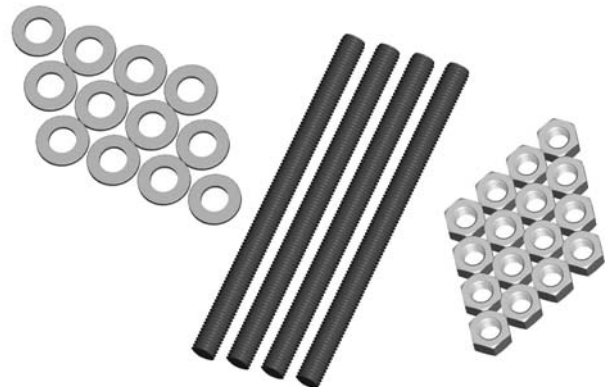

Casting into New Concrete

Before casting into new concrete, ensure the site is suitable for installation of a CPF25. The CPF25's Clean Cord Technology requires space behind the power stub-up for the Cord Management Kit (CMK). To ensure adequate space, refer to the CPF25 Installation Template (75-001163-01) stapled into the center of this installation guide.

IMPORTANT:

- Always check local codes to ensure compliance. You may need to adjust these instructions to comply with codes that apply at your installation location.
- The concrete block must measure at least 20" on all sides.
- The bolt threads must extend 2.5" above the concrete.
- The conduit must be 3/4" to 1 1/4" (maximum) in diameter and extend 12" above the concrete.
- The service wiring must extend 6' above surface.
- Refer to Section 2 of this installation guide for detailed instructions on how to install the pedestal mount.

Preparation

Before pouring the concrete pad, check to make sure that all pedestal mounting components are readily available at the installation site and that the conduit and service wiring is positioned as described on the installation template. It is recommended that a jig be created to position the conduit before pouring the concrete.

Follow These Steps

1. Install two nuts, with two washers captured between them, onto each of the four bolts, as illustrated. Lock them together so the lower end of the upper nut is located 6 - 6 1/2" from the bottom of the bolt. This sets the length of the exposed threads.
2. Insert the four bolts through the Plastic Bolt Installation Template. This ensures the relative position of the bolts and that the flange of the pole fits over the bolts.
3. On the bottom of each bolt, install a nut, a washer, and a nut. Lock the two nuts together so that the lower nut aligns to the bottom of the bolt.
4. Immediately after pouring the concrete, push the bolts into the concrete 6.5" deep, as illustrated. Ensure correct alignment and that the top 2.5" of the bolts remain exposed. Rotate the bolts as you insert them to draw concrete into the threads.
5. When the concrete is fully set, remove the upper nuts and one washer to install the pedestal's mounting post.

You are now ready to install the CPF25's pedestal mount as described in Section 2 of this installation guide.

Installing on Existing Concrete

If installing on existing concrete, perform the following tasks:

- Review the site for suitability to install a CPF25. The CPF25's Clean Cord Technology requires space behind the power stub-up for the Cord Management Kit (CMK). To ensure adequate space, reference the CPF25 Installation Template (75-001094-01) included in this installation kit.
- Review the dimensions of the existing concrete slab. To safely mount a CPF25 charging station, the concrete must be at least 6" thick. At this thickness, all of the CPF25's mounting bolts must be positioned at least 15" from the front edge, at least 12" from the side edges, and at least 6" from the rear edge of the concrete slab.
- If an existing charging station is already in place at the installation site, turn off all power to the station and disassemble according to the original manufacturer's instructions. Cut away any existing bolts or non-power conduit stub-up to ground level. You may need to plug cut-away conduits at the slab end, and disconnect wiring at the other end.

IMPORTANT: Always check local codes to ensure compliance. You may need to adjust these instructions to comply with codes that apply at your installation location.

Tools Required

Electric drill or Hammer drill (1/2" chuck may be required depending on drill bits used)

Consumables Required

Consumable	Purpose
Epoxy Adhesive for Concrete, 9.3 Ounce Cartridge (includes two mixing nozzles)	Filling drilled holes.
Mixing Nozzles for 9.3 Ounce Epoxy Adhesive for Concrete	Filling drilled holes. NOTE: You may need extra mixing nozzles to accommodate delays of over three minutes when applying epoxy.
Ratchet Rod Caulk Gun with Half-Barrel Frame for 10-13 Ounce Cartridge, 6:1 Thrust	Filling drilled holes. NOTE: Any standard caulk gun will work.
Electrical Cleaning and Maintenance Aerosol, Any Angle Spray Duster, 8 Ounce Net Weight	Cleaning drilled holes.
Slow Spiral Round-Shank Masonry Drill Bit, 3/4" diameter, 1/2" Shank, 10" Drill Depth, 12" Length Overall	Drilling 3/4" holes in concrete. NOTE: The holes must be at least 6" deep.
Drill Bit for Concrete Embedded Rebar, Round, 3/4" bit size, 1/2" Shank diameter, 12" Length Overall	Drilling 3/4" hole through rebar.
Nylon Loop-Handle Brush, 3/4" Brush Diameter, 3" Length Brush, 8 1/2" Length Overall	Cleaning drilled holes.
Push-on Round Cap, fits 5/8" - 11/16" OD, 1/2" Inside Height, Packs of 100	Keeping the epoxy inside the drilled holes in situations where the slab is only 6" deep.

Follow These Steps

1. Install two nuts with two washers captured between them. Lock them together so the lower end of the nut is located 6" from the bottom of the bolt. This sets the length of the exposed threads.
2. Use the Installation Template to mark the hole locations.
3. Remove the template and drill four 3/4" diameter holes 6" deep into the concrete. When locating the template, consider the station's total footprint. For reference, a template is included in this kit

NOTE:

- Bolts must be parallel after installation. Therefore, ensure drill holes are plumb by using a bubble level to check the angle of the drill after drilling 1 to 1 1/2".
- If installing over existing buried conduit, position the center of the template around the conduit stub-up.
- You may need two drill bits - one for the concrete (with the pilot) and another for the rebar (without the pilot). Always start the hole using the standard drill bit, then switch to the rebar drill bit only if drilling through rebar.

4. Remove all dust from inside the drilled holes using compressed air, or a vacuum and/or a brush.
5. If the concrete slab is only 6" deep, insert a plug in each hole to keep the epoxy in place until it hardens. Place the plug over the long end of a bolt and then use the bolt to push the plug to the bottom of the hole.
6. Fill each hole with epoxy to about 2 1/2" to 3" below the top. Continue immediately to the next step because the epoxy sets within about eight minutes.

NOTE: Inserting the threaded bolts displaces the epoxy, causing it to fill the holes to grade level. If the epoxy is below grade level, you can add more after the next step.

7. Place the Installation Template over the holes. This ensures the relative position of the bolts and that the flange of the pole fits over the bolts.
8. Insert the bolts through the template, into the holes. Rotate bolts as you insert them to draw epoxy into the threads.

IMPORTANT: Epoxy is very thick. Therefore, it is important to rotate the bolts as you insert them. This allows the epoxy to fully coat the threads of the bolts, reducing the amount of trapped air.

NOTE: You can leave the installation template in place.

9. If needed, top up the holes with epoxy to grade level.
10. Allow the epoxy to cure for at least 15 minutes* before removing the top nuts and washers and 45 minutes* before applying torque to the nuts.

**Epoxy cure times may vary depending on the type of epoxy you are using. Refer to the cure times provided with the epoxy.*

You are now ready to install the CPF25's pedestal mount as described in Section 2 of this installation guide.

Installing onto a Stacked Parking Platform

Before installing the CPF25 onto a stacked parking platform, ensure that the site is suitable. Every stacked parking platform is different. Therefore, instead of step-by-step instructions, ChargePoint provides the following guidelines:

- The CPF25's Clean Cord Technology requires at least 2" between the rear edge of the mounting plate and the wall to allow adequate clearance for the Cord Management Kit (CMK). Refer to the "Template, CPF25 Mount Placement with Clearance" stapled into the center of this installation guide.
- Before installing on the stacked parking platform, check to make sure that all pedestal mounting components are readily available at the installation site.
- Always check local codes to ensure compliance.
- Ensure you have adequate wiring. Service wiring for the CPF25 must extend six feet above the platform's surface (just like any other type of CPF25 installation).
- Refer to Section 2 of this installation guide for detailed instructions on how to install the pedestal mount. For stacked parking installations, it is acceptable to use a service cord (i.e. jacketed cable) without conduit inside the ChargePoint pedestal, provided the wiring is protected with appropriate bushings as it enters the pedestal.
- Ensure that the pedestal is stable and does not move excessively when the station is in use or when the platform is in motion.

Install the Power Share Kit

C

IMPORTANT !

Please note which units (as identified on the activation label) are sharing a circuit. The information on the activation labels, in addition to the breaker panel ID and breaker number, **MUST** be provided during the activation process (see Post-Installation Checklist on page 5-3).

Use the contents of the Power Share kit to connect a dual port charging station to a single circuit.

Kit Contents

If you ordered a power sharing kit, you will receive:

- Junction Box (1)
- Cover (1)
- 1/4" Self-Tapping Screws to attach junction box to pedestal (2)
- Screws to attach cover (2)
- Wire Nuts (2)
- Installation Instructions (repeated below)



DANGER: RISK OF SHOCK

Turn off circuit breaker.
Do not restore power until installation is complete.
Failure to follow these instructions could result in shock or electrocution.

Install the Power Share Kit

1. Using the two supplied screws, attach the junction box to the pedestal, as shown.
1. Run the L1 and L2 service wires into the hole in the bottom of the junction box.

NOTE: Maximum wire size is 6AWG.

1. Twist two 10-gauge wires (approximately 18" long) onto each of the service wires and secure using wire nuts.
1. Route a 10-gauge wire to each of the charging stations.
1. Attach the cover to the junction box by hand-tightening the two supplied screws.



Install or Replace Signs

D

Follow these steps in this appendix to install signs onto the charging station. To ensure a proper fit, signs must follow the specification provided by ChargePoint. An example of the sign specification (not to scale) is provided below. Detailed sign specifications are available at www.chargepoint.com/support-guides/. To ensure a proper fit, a replacement sign must be a maximum of 1 mm thick and must be 102 mm wide (length will depend on whether you are installing a sign on the front of the pedestal or on the cord management kit as well as which version of the cord management kit you are installing).

Installing a Front Sign on a Pedestal

It is easier to install the sign before installing the head assembly, but it can be installed with the head assembly already in place. Follow these steps to install the sign with the head assembly in place. If the head assembly is not installed, the installation steps are the same, with the exception of inserting the top edge of the sign under the bottom lip of the head assembly.

- Remove the tape from the adhesive strip on the back of the sign.
- With the adhesive strip facing toward the pedestal, insert the top left corner of the sign under the groove on the top left corner of the pedestal, sliding the sign upwards as far as possible to position the top of the sign under the bottom lip of the head assembly.
- Starting with the top left corner and working from top to bottom, use a thumb or finger to slide the left side of the sign under the pedestal's leftmost groove.
- When the left side of the sign is fully inserted, bow the top of the sign outward slightly to insert the top right corner of the sign under the groove on the top right corner of the pedestal, ensuring the top of sign remains positioned under the bottom lip of the head assembly.
- Starting with the top right corner and working from top to bottom, use your thumb or finger to slide the right side of the sign under the pedestal's rightmost groove.
- When the sign is fully inserted into the pedestal's left and right grooves, and under the bottom lip of the head assembly, run your hand down the center of the sign while applying enough pressure to make sure the sign's adhesive strip contacts the pedestal.

Installing a Top Sign on the Cord Management Kit (CMK)

To remove a sign after the station has been installed:

1. Use the L-wrench to loosen the set screw on each side of the top cap, as shown.
2. Pull the top assembly up and move it towards the back of the cord management assembly.
3. Slide the existing sign out of the grooves.

To install the new sign:

1. Slide the replacement sign into the grooves by bending it slightly.
2. Slide the sign all the way down, ensuring its bottom edge is located behind the plastic cap on the cord management assembly, as shown.
3. Re-install the top assembly. Remember to tighten the set screws.

Installing a Rear Sign on a Cord Management Kit (CMK)

Installing a sign on the rear side of the cord management assembly is the same as the instructions provided above for installing a bottom sign on a wall mounted cord management assembly.

Custom and Optional Signs

Detailed sign specifications for custom and optional signs are available at www.chargepoint.com/support-guides.php.

Sample Sign Dimensions
Top Sign on Front of CMK



Limited Product Warranty



This CPF25 Limited Product Warranty applies to you, a customer who has purchased CHARGEPOINT's CPF25 Charging Stations (the "Product") from CHARGEPOINT, INC., or one of its authorized distributors and not for resale.

LIMITED ONE-YEAR WARRANTY: Subject to the exclusions from warranty coverage set forth below, CHARGEPOINT warrants that the Product will be free from any defects in materials and/or workmanship (the "Limited Warranty") for a period of one (1) year after the date of the initial installation of the Product (the "One-Year Warranty Period"). If the Product becomes defective in breach of the Limited Warranty, CHARGEPOINT will, upon written notice of the defect received during the One-Year Warranty period, either repair or replace, at ChargePoint's election, the Product if it proves to be defective; provided, that CHARGEPOINT will not be responsible for the cost of any labor associated with the repair or replacement of any defective Product. If Customer has acquired the Product and has executed a multi-family ChargePoint Electric Vehicle Charging Services Agreement, the effective time period for the Limited Warranty is pursuant to that agreement.

TWO-, THREE-, FOUR- OR FIVE-YEAR EXTENDED WARRANTY (Additional Charge Applies): Subject to the exclusions from warranty coverage set forth below, if you have purchased an extended warranty, and if the Product becomes defective in breach of the Limited Warranty above at any time during the extended warranty period after the date of the initial installation of the Product, CHARGEPOINT will, upon written notice of the defect received during the extended warranty period, either repair, provide replacement parts for the defective parts of the Product or replace the Product, at ChargePoint's election, if it proves to be defective; provided, that CHARGEPOINT will not be responsible for the cost of any labor associated with the repair or replacement of any defective Product.

CHARGEPOINT's Options: You acknowledge that replacement products provided by CHARGEPOINT under each of the Limited Warranty and the Extended Warranty may be re-manufactured or reconditioned Products or, if the exact Product is no longer manufactured by CHARGEPOINT, a Product with substantially similar functionality ("Replacement Products"). Any Replacement Products so furnished will be warranted for the remainder of the original Warranty Period or ninety (90) days from the date of delivery of such Replacement Product, whichever is greater. Should CHARGEPOINT be unable to repair or replace the Product, CHARGEPOINT will refund the purchase price of the Product.

EXCLUSIONS FROM LIMITED WARRANTY AND EXTENDED WARRANTY

IMPORTANT: The Limited Warranty and, if purchased, the Extended Warranty, on your Product shall not apply to defects, or service repairs, resulting from any of the following:

- Alteration or modification of the Product in any way not approved in writing by CHARGEPOINT.
- Vandalism.
- Abuse, damage or otherwise being subjected to problems caused by negligence (including but not limited to physical damage from being struck by a vehicle) or misapplication, or use of the Products other than as specified in the applicable CHARGEPOINT documentation.
- Installation or relocation of the Products unless performed by CHARGEPOINT or by a ChargePoint authorized installer or service provider.
- Improper site preparation or maintenance.
- Damage as a result of accidents, extreme power surge, extreme electromagnetic field, acts of nature or other causes beyond the control of CHARGEPOINT.
- Use of the Product with software, interfacing, parts or supplies not supplied by CHARGEPOINT.

You are responsible for the proper installation and maintenance of the Product. Any service or repairs beyond the scope of the Limited Warranty or the Extended Warranty above are subject to CHARGEPOINT's then prevailing current labor rates and other applicable charges.

Third Party Products. The Limited Warranty and Extended Warranty are exclusive of products manufactured by third parties ("Third Party Products"). If such third party manufacturer provides a separate warranty with respect to the Third Party Product, CHARGEPOINT will include such warranty in the packaging of the CHARGEPOINT Product.

OBTAINING WARRANTY SERVICE

To obtain warranty service you must: (a) obtain a return materials authorization number (“RMA#”) from CHARGEPOINT by contacting 1-877-370-3802 (or for customers outside the U.S., contact 408-370-3802) and ask for Customer Service, and (b) deliver the Product, in accordance with the instructions provided by CHARGEPOINT, along with proof of purchase in the form of a copy of the bill of sale including the Product’s serial number, contact information, RMA# and detailed description of the defect, in either its original package or packaging providing the Product with a degree of protection equivalent to that of the original packaging, to CHARGEPOINT at the address below. You agree to obtain adequate insurance to cover loss or damage to the Product during shipment.

If you obtain an RMA# and return the defective Product as described above, CHARGEPOINT will pay the cost of returning the Product to CHARGEPOINT. Otherwise, you agree to bear such cost, and prior to receipt by CHARGEPOINT, you assume risk of any loss or damage to the Product. CHARGEPOINT is responsible for the cost of return shipment to you if the CHARGEPOINT Product is found to be defective.

Returned products which are found by CHARGEPOINT to be not defective, returned out-of-warranty or otherwise ineligible for warranty service will be repaired or replaced at CHARGEPOINT’s standard charges and shipped back to you at your expense.

At CHARGEPOINT’s sole option, CHARGEPOINT may perform repair service on the Product at your facility, and you agree to provide CHARGEPOINT with all reasonable access to such facility and the Product, as required. On-site repair service is not available outside the United States.

All replaced parts, whether under warranty or not, are the property of CHARGEPOINT.

WARRANTY LIMITATIONS

THE LIMITED WARRANTY SET FORTH ABOVE IS EXCLUSIVE AND NO OTHER WARRANTY, WHETHER WRITTEN OR ORAL, IS EXPRESSED OR IMPLIED BY CHARGEPOINT, TO THE MAXIMUM EXTENT PERMITTED BY LAW. THERE ARE NO OTHER WARRANTIES RESPECTING THE PRODUCT AND DOCUMENTATION AND SERVICES PROVIDED UNDER THIS AGREEMENT, INCLUDING WITHOUT LIMITATION ANY WARRANTY OF DESIGN, MERCHANTABILITY, FITNESS FOR A PARTICULAR PURPOSE (EVEN IF CHARGEPOINT OR DISTRIBUTOR HAS BEEN INFORMED OF SUCH PURPOSE) OR AGAINST INFRINGEMENT.

Some states or jurisdictions do not allow the exclusion of express or implied warranties so the above exclusions may not apply to you. IF ANY IMPLIED WARRANTY CANNOT BE DISCLAIMED UNDER APPLICABLE LAW, THEN SUCH IMPLIED WARRANTY SHALL BE LIMITED IN DURATION TO THE LIMITED WARRANTY PERIOD DESCRIBED ABOVE. NO WARRANTIES APPLY AFTER THE TOTAL WARRANTY PERIOD. Some states or jurisdictions do not allow limitations on how long an implied warranty lasts, so the above limitation may not apply to you.

NO AGENT OF CHARGEPOINT IS AUTHORIZED TO ALTER OR EXCEED THE WARRANTY OBLIGATIONS OF CHARGEPOINT.

CHARGEPOINT SPECIFICALLY DOES NOT WARRANT THAT ANY SOFTWARE WILL BE ERROR FREE OR OPERATE WITHOUT INTERRUPTION.

THE REMEDIES IN THIS LIMITED PRODUCT WARRANTY ARE YOUR SOLE AND EXCLUSIVE REMEDIES.

LIMITATIONS OF LIABILITY

You acknowledge and agree that the consideration which you paid to CHARGEPOINT or one of its authorized distributors does not include any consideration by CHARGEPOINT or one of its authorized distributors of the risk of consequential, indirect or incidental damages which may arise in connection with your use of, or inability to use, the Product. **THUS, CHARGEPOINT OR ONE OF ITS AUTHORIZED DISTRIBUTORS WILL NOT BE LIABLE FOR ANY INDIRECT, INCIDENTAL, SPECIAL, PUNITIVE OR CONSEQUENTIAL DAMAGES, INCLUDING WITHOUT LIMITATION LOST PROFITS, LOST BUSINESS, LOST DATA, LOSS OF USE, OR COST OF COVER INCURRED BY YOU ARISING OUT OF OR RELATED TO YOUR PURCHASE OR USE OF, OR INABILITY TO USE, THIS PRODUCT OR THE SERVICES, UNDER ANY THEORY OF LIABILITY, WHETHER IN AN ACTION IN CONTRACT, STRICT LIABILITY, TORT (INCLUDING NEGLIGENCE) OR OTHER LEGAL OR EQUITABLE THEORY, EVEN IF C CHARGEPOINT KNEW OR SHOULD HAVE KNOWN OF THE POSSIBILITY OF SUCH DAMAGES. IN ANY EVENT, THE CUMULATIVE LIABILITY OF CHARGEPOINT OR ONE OF ITS AUTHORIZED DISTRIBUTORS FOR ALL CLAIMS WHATSOEVER RELATED TO THIS PRODUCT OR THE SERVICE WILL NOT EXCEED THE PRICE YOU PAID FOR THIS PRODUCT.**

THE LIMITATIONS SET FORTH HEREIN ARE INTENDED TO LIMIT THE LIABILITY OF CHARGEPOINT AND SHALL APPLY NOTWITHSTANDING ANY FAILURE OF ESSENTIAL PURPOSE OF ANY LIMITED REMEDY.

Some states or jurisdictions do not allow the exclusion or limitation of incidental or consequential damages, so the above limitation or exclusion may not apply to you.

THIS LIMITED PRODUCT WARRANTY GIVES YOU SPECIFIC LEGAL RIGHTS AND YOU MAY ALSO HAVE OTHER RIGHTS WHICH VARY FROM STATE TO STATE OR JURISDICTION TO JURISDICTION.

ADDITIONAL INFORMATION

This Limited Product Warranty is valid for U.S.A. and Canada only.

This Limited Product Warranty shall be governed by and construed in accordance with the laws of the State of California, U.S.A., exclusive of its conflict of laws principles. The U.N. Convention on Contracts for the International Sale of Goods shall not apply.

This Limited Product Warranty is the entire and exclusive agreement between you and CHARGEPOINT with respect to its subject matter, and any modification or waiver of any provision of this statement is not effective unless expressly set forth in writing by an authorized representative of CHARGEPOINT.

The Limited Product Warranty is not transferable by you to anyone else.

All inquiries or claims made under this Limited Product Warranty must be sent to CHARGEPOINT's address as follows:

ChargePoint, Inc.
254 East Hacienda Avenue
Campbell, CA 95008 USA
Tel: 408-370-3802
Fax: 408-370-3847
Email: service@chargepoint.com

SAVE THESE IMPORTANT SAFETY INSTRUCTIONS

This manual contains important instructions that must be followed during installation of a ChargePoint® Networked Charging Station.

Grounding instructions

The ChargePoint® Charging Station must be connected to a grounded, metal, permanent wiring system; or an equipment-grounding conductor is to be run with circuit conductors and connected to the equipment grounding terminal or lead on the Electric Vehicle Supply Equipment (EVSE). Connections to the EVSE shall comply with all applicable codes and ordinances.

FCC Compliance Statement

This equipment has been tested and found to comply with the limits for a Class B digital device pursuant to Part 15 of the FCC Rules. These limits are designed to provide reasonable protection against harmful interference when the equipment is operated in a commercial environment. This equipment generates, uses, and can radiate radio frequency energy and, if not installed and used in accordance with the manufacturer's instruction manual, may cause harmful interference with radio communications. Operation of this equipment in a residential area is likely to cause harmful interference, in which case, you will be required to correct the interference at your own expense.

Important: Changes or modifications to this product not authorized by ChargePoint, Inc., could affect the EMC compliance and revoke your authority to operate this product.

Exposure to Radio Frequency Energy: The radiated power output of the 802.11 b/g/n radio and cellular modem (optional) in this device is below the FCC radio frequency exposure limits for uncontrolled equipment. This device should be operated with a minimum distance of at least 20 cm between the 802.11 b/g/n and cellular antennas and a person's body and must not be co-located or operated with any other antenna or transmitter by the manufacturer, subject to the conditions of the FCC Grant.

Industry Canada

This device complies with Industry Canada license-exempt RSS standard(s). Operation is subject to the following two conditions: (1) this device may not cause interference, and (2) this device must accept any interference, including interference that may cause undesired operation of the device.

Le présent appareil est conforme aux CNR d'Industrie Canada applicables aux appareils radio exempts de licence. L'exploitation est autorisée aux deux conditions suivantes : (1) l'appareil ne doit pas produire de brouillage, et (2) l'utilisateur de l'appareil doit accepter tout brouillage radioélectrique subi, même si le brouillage est susceptible d'en compromettre le fonctionnement.

FCC/IC Compliance Labels

Go to <http://www.chargepoint.com/labels/>.

Safety and compliance

This document provides instructions to install the ChargePoint® Charging Station and should not be used for any other product. Before installing the ChargePoint® Charging Station, you should review this manual carefully and consult with a licensed contractor, licensed electrician and trained installation expert to ensure compliance with local building practices, climate conditions, safety standards, and all applicable codes and ordinances.

The ChargePoint® Charging Station should be installed only by a licensed contractor and a licensed electrician and in accordance with all local and national codes and standards. The ChargePoint® Charging Station should be inspected by a qualified installer prior to the initial use. Under no circumstances will compliance with the information in this manual relieve the user of his/her responsibility to comply with all applicable codes or safety standards. This document describes the most commonly-used installation and mounting scenarios. If situations arise in which it is not possible to perform an installation following the procedures provided in this document, contact ChargePoint, Inc. ChargePoint, Inc. is not responsible for any damages that may occur resulting from custom installations that are not described in this document.

No accuracy guarantee

Reasonable effort was made to ensure that the specifications and other information in this manual are accurate and complete at the time of its publication. However, the specifications and other information in this manual are subject to change at any time without prior notice.

Warranty information and disclaimer

Your use of, or modification to, the ChargePoint® Charging Station in a manner in which the ChargePoint® Charging Station is not intended to be used or modified will void the limited warranty. Other than any such limited warranty, the ChargePoint products are provided "AS IS," and ChargePoint, Inc. and its distributors expressly disclaim all implied warranties, including any warranty of design, merchantability, fitness for a particular purposes and non-infringement, to the maximum extent permitted by law.

Limitation of liability

IN NO EVENT SHALL CHARGEPOINT, INC. OR ITS AUTHORIZED DISTRIBUTORS BE LIABLE FOR ANY INDIRECT, INCIDENTAL, SPECIAL, PUNITIVE, OR CONSEQUENTIAL DAMAGES, INCLUDING WITHOUT LIMITATION, LOST PROFITS, LOST DATA, LOSS OF USE, COST OF COVER, OR LOSS OR DAMAGE TO THE CHARGEPOINT® CHARGING STATION, ARISING OUT OF OR RELATING TO THE USE OR INABILITY TO USE THIS MANUAL, EVEN IF CHARGEPOINT, INC. OR ITS AUTHORIZED DISTRIBUTORS HAVE BEEN ADVISED OF THE POSSIBILITY OF SUCH DAMAGES.

Copyright and trademarks

©2016 ChargePoint, Inc. All rights reserved. This material is protected by the copyright laws of the United States and other countries. It may not be modified, reproduced or distributed without the prior, express written consent of ChargePoint, Inc. CHARGEPOINT is a U.S. and European Union registered trademark and service mark of ChargePoint, Inc. and can not be used without the prior written consent of ChargePoint. All other products or services mentioned are the trademarks, service marks, registered trademarks or registered service marks of their respective holders. ChargePoint, Inc. has several patents filed.



254 East Hacienda Avenue
Campbell, CA 95008 USA
US toll free: +1-877-850-4562
www.chargepoint.com

Document Part Number: 75-001164-01 Rev. 3